

TAD880-884VE

7.7 liter, in-line 6 cylinder - 160, 185, 210, 235 and 250 kW
EU Stage V

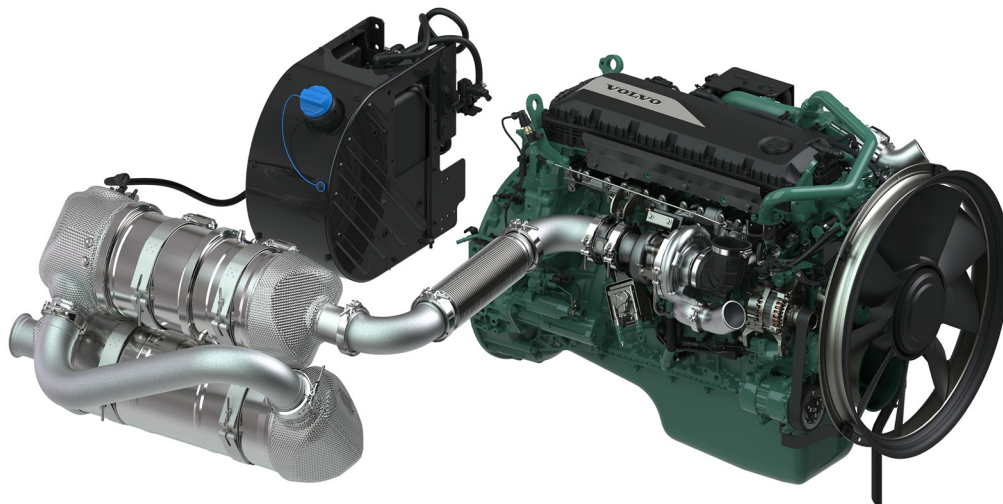

TAD880-884VE is a powerful, reliable and fuel efficient off-road Diesel Engine range built on the Volvo in-line six concept.

Low cost of ownership

World class fuel efficiency combined with a reliable Exhaust Aftertreatment System (EATS) gives high uptime as well as low cost of ownership.

Compact & simple installation

System concepts lowers amount of cooling capacity needed hence minimizing radiator size. Interfaces are compatible with engines of earlier legislations. Installation guidelines as well as drawings and CAD models are easy to access.

Material needed in order to install the engine can be ordered as optional equipment from Volvo Penta. The result is an engine and EATS that is easy to install and operate.

Durability & low noise

Long experience with DPF/SCR systems in combination with great knowledge of base engine development reduces risk of downtime. The in-line six cylinder engine together with common rail system produces smooth operation with low noise.

Power & torque

Maximum torque is reached at low rpm and continues to rated power. The power and torque layout ensures the engine to operate in a wide engine speed range.

Low exhaust emission

Chosen engine design combined with optimized DPF/SCR technology ensures that TAD880-884VE complies with EU Stage V emissions.

Easy service & maintenance

Easily accessible service and maintenance points contribute to the ease of service of the engine. As optional equipment remotely mounted filters and service points can be chosen.

- Proven and straight-forward design - built on Volvo Group technology
- High torque already at low engine speed
- SCR, DPF+DOC and uncooled EGR
- Compact, simple installation and easy to service
- Same engine footprint for all emission standards
- Wide range of optional equipment
- Excellent passive soot regeneration
- Extended oil service intervals 1000h

	TAD880VE	TAD881VE	TAD882VE	TAD883VE	TAD884VE
Power output, kW/hp	160/218	185/252	210/286	235/320	250/340
at speed, rpm	2210	2210	2210	2210	2210
Max. torque, Nm/lb/ft	1050/774	1150/848	1225/904	1300/959	1330/981
at speed, rpm	1400	1400	1400	1400	1400
Min. idling speed, rpm	600	600	600	600	600

TAD880-884VE

7.7 liter, in-line 6 cylinder - 160, 185, 210, 235 and 250 kW
EU Stage V

Technical data

Configuration and no. of cylindersin-line 6
Displacement, l (in³)..... 7.7 (470)
Method of operation4-stroke
Bore, mm (in.)110 (4.33)
Stroke, mm (in.)..... 135 (5.31)
Dry weight ^{*}), engine only, kg (lb)..... 703 (1550)
Compression ratio..... 17.2:1
Direction of rotation (viewed towards flywheel).....counterclockwise

^{*}) The engine is weighed with components that consist of the minimum running weight including standard flywheel and excluding cooling package, hoses and air filters.

Technical description

Engine and block

- Cast iron cylinder block
- Replaceable valve guides and valve seats
- Overhead camshaft and four valves per cylinder

Lubrication system

- Full flow cartridge insert filter
- Gear type lubricating oil pump, gear driven

Fuel system

- Electronically controlled common rail injectors
- Gear driven fuel feed pump
- Electronically controlled common rail injectors
- Fuel pre filter with water separator and water-in-fuel indicator/ alarm
- Manual feed pump on pre filter

Cooling system

- Belt driven coolant pump with high degree of efficiency

Electrical system

- Engine Management System (EMS) 2.4, includes advanced features for diagnostics and fault tracing.
- The instruments and controls connect to the engine via the CAN SAE J1939 interface. Options available for engine control equipment.

Exhaust after treatment system

- SCR, DPF+ DOC and uncooled EGR
- Airless urea injection
- Wide range of options available, including different sized AUS/ DEF tanks (also possible for OEM to design own tank).
- AUS/DEF Quality Level Temperature Sensor

Dimensions

Not for installation. Dimensions in mm.

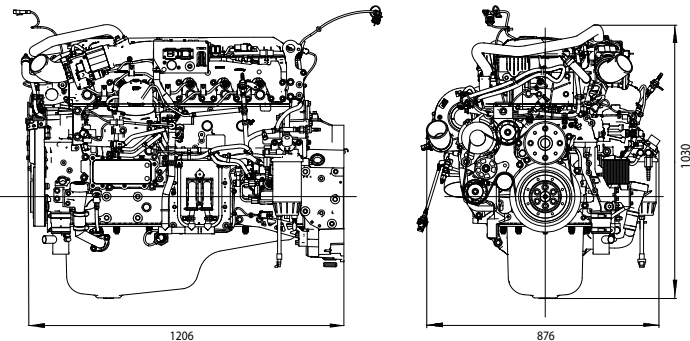

Please note that products illustrated may differ from production models.

Not all models and accessories are available in all markets, and standard equipment may vary between different markets. Every effort has been made to ensure that facts and figures are correct at the time of publication. However, Volvo Penta reserves the right to make changes without prior notice at any time.

Main components

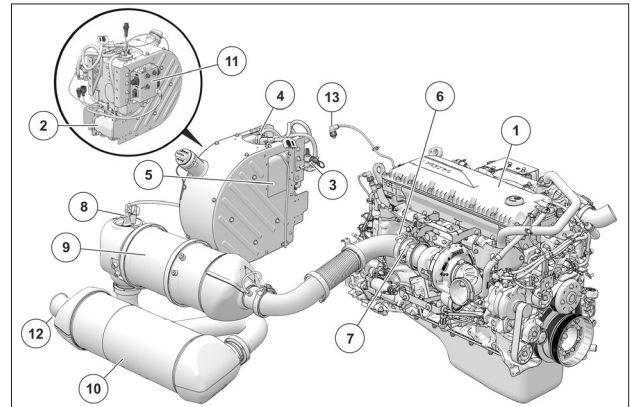

1. Engine with common rail fuel injection
2. AdBlue Pump Unit
3. Solenoid Valve, heating
4. Tank armature with sensors and heater
5. AdBlue tank, heated
6. NOx Sensor
7. Electrical Exhaust Pressure Governor
8. Dosage Valve
9. Diesel particulate filter
10. Muffler with Catalytic Converter
11. After treatment Control Module (ACM)
12. NOx Sensor
13. Air inlet Temperature Sensor and pressure sensor

All necessary components are available in various lengths and sizes, cables, heated hoses and tanks. A complete system.

Characteristics

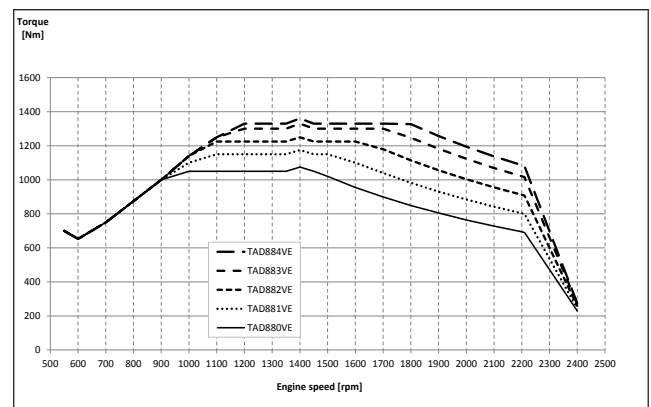
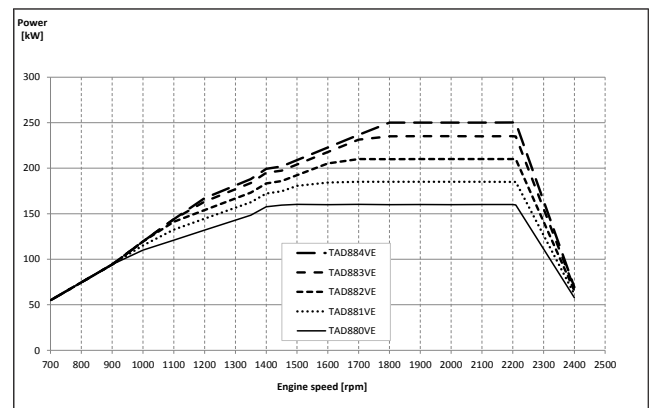

AB Volvo Penta

SE-405 08 Göteborg, Sweden
www.volvopenta.com